



COLONNA 400

Use and maintenance booklet

SERIAL NUMBER M

USE AND MAINTENANCE MANUAL

“COLONNA 400”

CONTENTS

Introduction.....	3
Safety instructions.....	4
Machine description	6
Operating Instructions	8
Maintenance	9
Warranty	10
Technical data sheet	11
Spare Parts.....	11
Declaration of Conformity.....	14

CAUTION! Keep this BOOKLET with care at all times

INTRODUCTION

The use and maintenance manual for the support, collects all the information related to the optimal use of the machine under conditions that promote the operator's safety.

This manual contains a lot of IMPORTANT information for the installation, use, storage and maintenance of the machine.

For more information you can always contact the MAXIMA's offices at the following numbers:

Tel: 0522-968011

Fax: 0522-967536

This manual should be read carefully by any operator using the column for the first time. This can prevent dangerous situations at the workplace.

This booklet is valid only for Colonna 400. The model is indicated on the support plate.

This booklet is written in accordance with EC regulations and related technical standards. See also the EC declaration provided on page 16

SAFETY INSTRUCTIONS

INTRODUCTION

The following safety instructions should be followed when using the support to reduce the risk of fire, short circuit and physical injury.

Before using the machine, please read the following information carefully and pay attention to the warnings given.

SAFETY

Do not bring water near electrical devices.

Prevent drips and any water spills or inadvertent disconnections of pipes containing liquid substances. Be careful of cold water while cutting at a height. Carefully remove cold water for example with a professional vacuum cleaner. Dry electrical wiring, plugs, etc.....

Consider the work environment.

Look carefully at what you are about to do. Use common sense. Do not use the machine when tired or distracted. Make sure you can always turn off the motor in an emergency. Do not use the machine if the ON/OFF button does not work properly.

PERSONAL PROTECTION

Proper clothing

Do not wear loose clothing or jewellery because they can hinder body movements. When working outside, rubber shoes are recommended instead of slippery footwear. Wear protection for long hair.

Use of personal protective equipment

Wear a hard hat against any falling pieces, protective gloves against sharp objects and goggles against concrete chips. Use a mouth and nose mask if necessary. The use of earplugs is mandatory for noise above 90dB(A).

SUPPORT

Use the support correctly and do not force it

Use the support only for the purposes for which it is intended. It is better and safer to use core bits with the appropriate diameter and the corresponding recommended speed.

Avoid unintended starts

Place the motor button in the OFF position and unplug the machine when not in use or during maintenance work or replacement of accessories. Check whether the machine is in the OFF position before plugging the power cable into the socket.

Carefully service the machinery

Carefully store the machinery and keep it clean for better and safer performance. Follow the maintenance instructions carefully. Keep handles dry of oils and grease at all times.

Safeguard the support from damage

Check the alignment and edge of moving parts. Breakages or other such conditions can affect normal use of the machinery.

Use of accessories

Use of accessories not specified in this manual may pose a risk or cause physical injury.

Use of electric cords or cables

Use only undamaged extension cords sufficiently long to work comfortably outdoors. Uncoil the power cord completely to prevent it from overheating. Do not bring the machine too close to the power cord or pull the cord to remove the plug from the power socket. Protect the power cord from sources of heat, oil and sharp edges.

Have the machinery repaired only by skilled operators

Electrical machinery must be up to safety standards, and only skilled operators can perform certain repair operations.

THE WORKPLACE

Cleanliness of the workplace

A cluttered environment can cause damage. Do not allow animals or people not involved in the work to enter the workplace because they may come into contact with the machinery. Collect cement pieces when drilling. When the machine is not in use, it should be kept in a dry place and out of the reach of children.

Safety in the workplace

Mount accessories properly to prevent them from coming loose or falling off. Check that all keys have been removed from the machine at the time of use. Ensure that all safety guards are properly installed to prevent damage. Maintain proper balance and a proper support point every time you use the machine.

Consider the situation of the work environment

Keep the workplace clean. Pay attention to all cables (underground and underfloor), pipes and rebars in the working position. Do not use electricity in the presence of flammable liquids or gases or in wet and rainy conditions.

EXPLANATION OF SYMBOLS USED



IGNORING IT CAN CAUSE SERIOUS PHYSICAL DAMAGE!

COLUMN DESCRIPTION

COMPOSITION OF THE MACHINE

The column consists of the following parts:

1. Base
2. Wheels
3. Stabilization rod
4. Handle
5. Column
6. Winch
7. Motor drill support
8. Feet

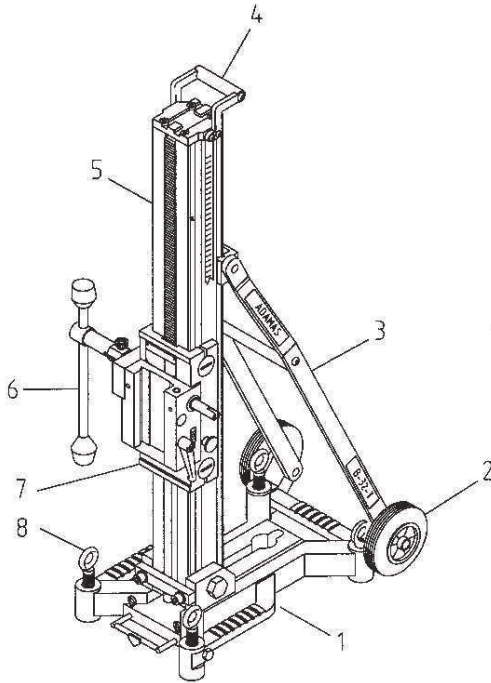

FUNCTIONS

General

Colonna 400 is designed for the use of diamond core bits. It can be used to drill concrete, asphalt and other similar stones. The maximum diameter of the core bits that can be used with this column is 400 mm.



The column should never be used for purposes other than those mentioned above

COLONNA 400

Motor drill support

The motor drill support (7) provides the motor itself and the diamond core bit with stable control while drilling. The drilling depth (5) and inclination are indicated on the column (6). The support is equipped with a brake (3) to secure the column in the highest position, a plastic threaded screw (1) and two spirit levels (2). Use the handle (4) to secure the motor drill. Colonna 400 is suitable for both right- and left-handed users: the winch side (8) can be placed either to the right or left of the motor drill support.

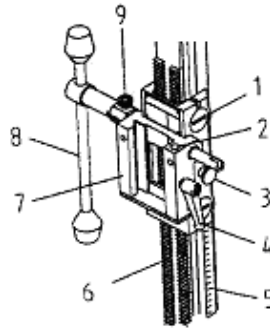

Base

The base provides stability and levels the column, which can be placed on the ground or vertically against a wall in two ways:

- Using a plug with a M12 bush

Bolts located on the base are used to level the base on the ground or on the wall. To level on the ground or wall use the spirit level located on the motor drill support.

Centring

Once ascertained through drawings, tests with instrumentation suitable for detecting under-wall pipes and cables, that the coring area is clear, mark the drilling position.

With a drill suitable for the material to be drilled, place a 15x50mm plug with M12 thread at a distance from the core drilling point of 350mm plus the distance of the axis of the motor drill from the support:

Transport

Colonna 400 is easy to move thanks to the handle located on the base and the top of the rack.

Column inclination

The column can be variously tilted to a maximum of 45° by loosening bolts (7), (8) and (9). To fix it in the desired position, tighten bolts (8) and (9).

Core drilling motor

A stand-mounted core drill can be used with colonna 400 via the motor plate. It is important to take into consideration the diameter and rpm of the core bit. Manual coring machines can be mounted with a special motor support.

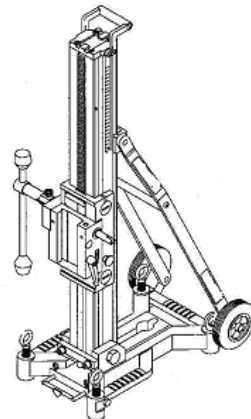

OPERATING INSTRUCTIONS

POSITIONING OF THE MACHINE

Support anchorage

- Insert an M12 plug into the wall or floor.
- Position the base and fix it with an M12 bush.

A telescopic extension can be used for additional anchorages

Levelling and inclining the column

Level the base by means of the bolts located on the same by checking the levels. If you need to drill a hole in a corner, loosen the top two bolts, tilt the column and tighten them.

Mount the motor drill and the diamond core bit

- Slide the support to the highest position : it will automatically lock.
- The support can be unlocked by pulling the swivel button located on it.
- Screw the motor plate to the motor and secure it carefully.
- Screw the diamond core bit to the motor drill chuck.
- Insert a hose to the water valve and connect it to the water source. Open the water tap (Do not use dirty water).
- Always drain the water so that it flows out of the hose. Electrical cables and plugs must absolutely not come in contact with water. When drilling overhead or on walls, always use a water catcher to prevent water spillage.
- Always follow these safety rules and keep the booklet handy.

MAINTENANCE

PREVENTIVE MAINTENANCE

Regardless of preventive maintenance, operator safety and machine life can be enhanced by following the tips below:

- Handle the machine with care
- Keep the machinery clean
- Carry the machine in wooden packaging
- Oil the gears of the machinery, and when not used for a long time, store it in a dry place.

Transport the machine in the core drill boxes (optional).

MAINTENANCE

In general, to ensure safety for the operator and long service life for the machinery, careful maintenance is required, i.e., cleaning, checking and lubricating the gears.

	<p>UNPLUG THE MOTOR DRILL DURING MAINTENANCE OR REPAIR JOBS. PROTECT THE ELECTRICAL PARTS OF THE MOTOR DRILL WHILE CLEANING</p>
---	--

In general, to ensure safety for the operator and long service life for the machinery, careful maintenance is required, i.e., cleaning, checking and lubricating the gears.

FREQUENCY	JOB	NOTES
After each drilling	Clean: <ul style="list-style-type: none"> • the guide • quick release system 	With water With water and lubricating oil
Weekly	General control: <ul style="list-style-type: none"> • failures 	
	Control of the slide block: <ul style="list-style-type: none"> • adjustment • wear 	Adjust if necessary Replace if necessary
Periodically (once a month)	Lubricate: <ul style="list-style-type: none"> • rack • levelling bolts 	
Annually	Support overhaul	Contact Maxima SpA

COLONNA 400

REPAIR AND REPLACEMENT OF SLIDING BLOCKS

Sliding block repair

Due to the friction between the block (1) and the column, the sliding block tends to wear. After a while this forms a "gap" between the block and the slide in the column.

The vacuum can be removed:

1. loosening the screw (3) with an Allen wrench
2. properly tightening the adjustment screw (2)
3. putting the screw (3) back in again

Replacement of the sliding block

When the sliding block (1) cannot be repaired any more, it must be replaced. Remove the two screws (3 and 2) and replace the four sliding blocks.

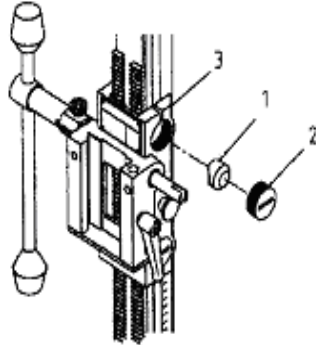

WASTE DISPOSAL

Please safeguard the environment when disposing of the waste.

WARRANTY

Period

Colonna 400 is covered by a 12-month warranty from the date of purchase

Contents of the warranty

Products found to be defective before or at the beginning of use will be repaired or replaced free of charge.

Transportation costs will always be borne by the customer.

The Maxima warranty does not apply when:

- the machine is overloaded
- the column is used for unintended purposes
- maintenance is not performed
- the operator does not follow the instructions in the instruction manual
- the column is used by unauthorised personnel
- the column is repaired without the use of Maxima accessories
- consumables

Warranty conditions

When necessary we may ask you to send the column back to us. Transportation costs will be borne by you. To perform a repair, we need a letter with the description of the problem by fax to No: **0522/967536**. Make sure the column is packed with sufficient protective materials to prevent damage during transport.

Repairs covered by warranty are performed free of charge. The warranty period cannot be extended after the repair has taken place.

Repairs will be made using original Maxima spare parts.

TECHNICAL DATA SHEET

DIMENSIONS

Length	520 mm
Width	380 mm
Height.....	980 mm
Weight	19.5 kg

TECHNICAL DATA

Motor support mounts a water core drill.....	
Diamond core bit.....	Ø 400 mm
Length of the diamond core bit	Max 450 mm

SPARE PARTS

When ordering spare parts and accessories we need the following information to provide them to you correctly:

- Type of machine and serial number found on the support base.
- The number of the item to be replaced is found in owing exploded views.

COLONNA 400

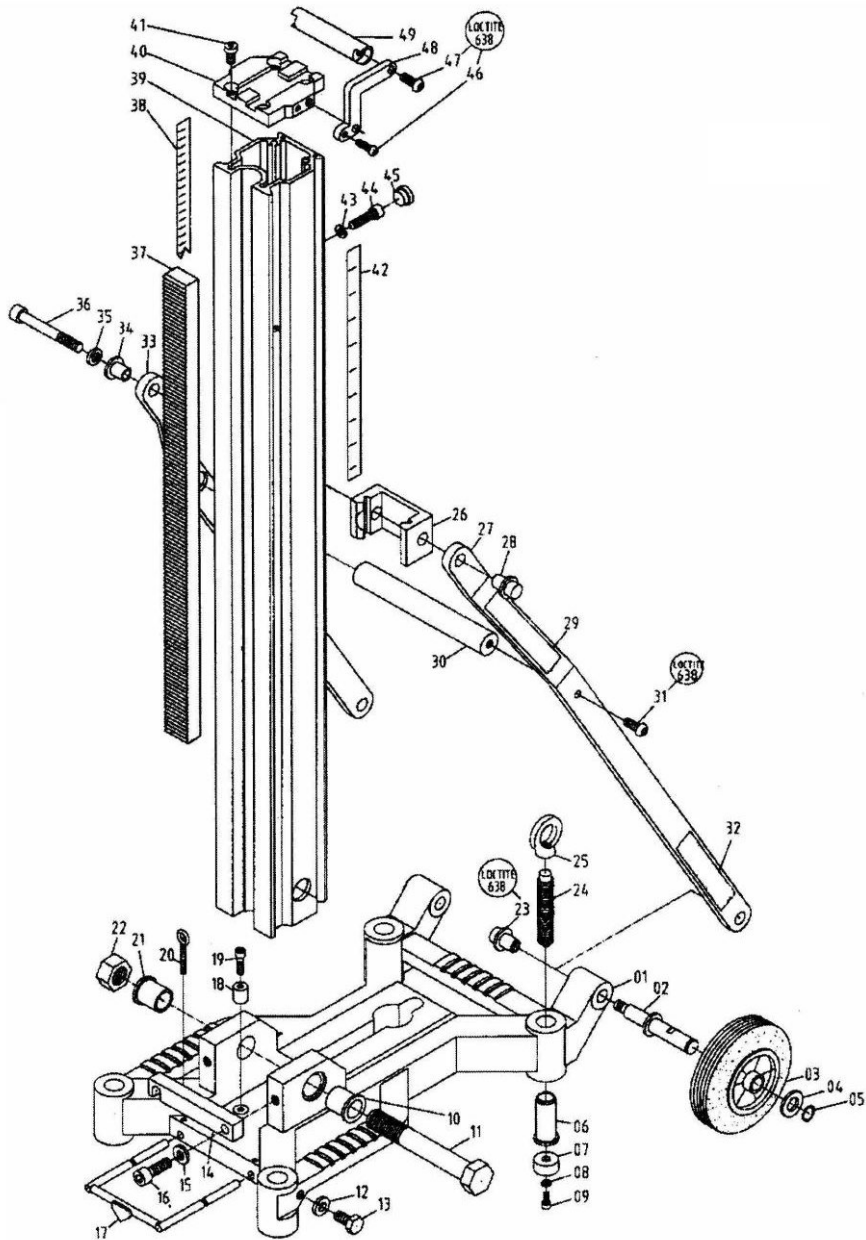

COLONNA 400

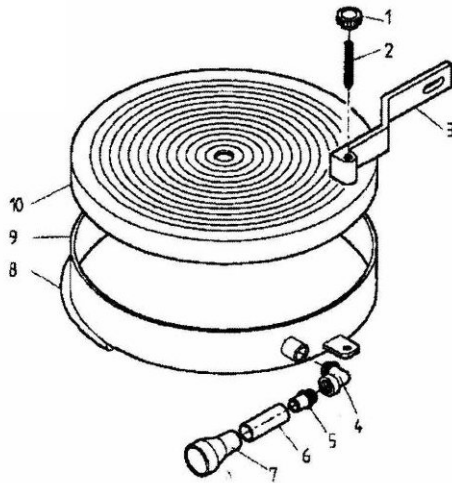
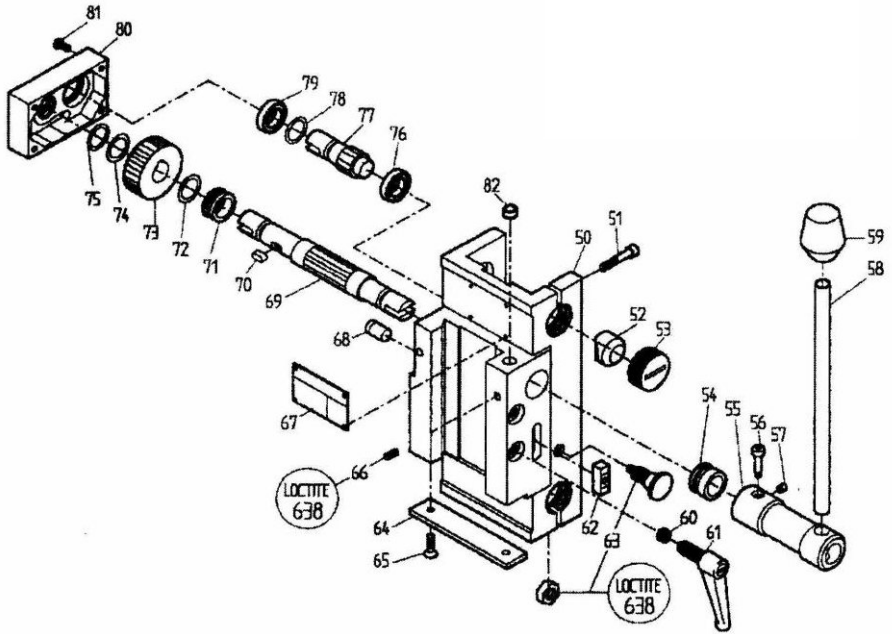

COLONNA 400

Declaration of Conformity 	We declare under our sole responsibility that this product complies with the following EC directives 98/37 EEC 89/392/EEC and amendments. 93/68 EEC EN291-1, EN292-2, EN292-2/A1, EN60204.1
Type Model	COLONNA 400 COL 400 INC
Serial Number	
Distributor	MAXIMA S.p.A. Via Matteotti 42028 Poviglio (RE) Tel: 0522-968011 - Fax: 0522-967536 www.maxima-dia.com info@maxima-dia.com



A handwritten signature in black ink, appearing to read "Mirco Dall'olio".

CEO
i.t. Mirco Dall'olio





Maxima SpA- Via Matteotti, 6 - 42028 Poviglio (Re) Italy
Tel: 0039 0522 968011 - Fax: 0039 0522 967536
info@maxima-dia.com - www.maxima-dia.com